

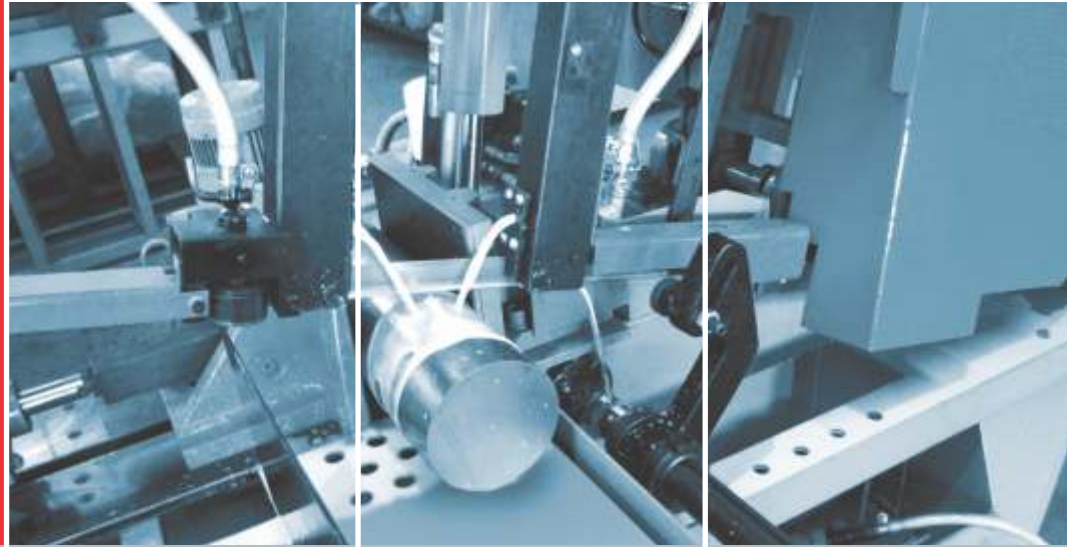

SPM TOOLS

Semi
Automatic



Horizontal Band Sawing Machine

FCM-245

"SPM" Horizontal high speed metal cutting Band saw Machine, Model FCM-245 is a Semi Automatic machine, swing type in construction, capacity upto 245Ø mm. The machine base and frame are made of heavy weld steel & is torsion and vibration free.

The machine is equipped with an infinitely variable speed drive from 24 to 100 m/min. is offered as a standard. For setting the length, the machine is provided with a sturdy swing type Bar-stop. The bar feeding has to be done manually.

This model is low cost machine, ideally suited to small industries and for cutting variety of small batch quantity steels as well as non-ferrous materials. The machine is fully protected to give maximum safety & prevent accidents. The bandsaw has a centralized control panel conveniently placed within operator's reach & a power driven brush for chip removal.

To reduce operators fatigue, the machine is provided with Hydraulic vice clamping and automatic arm lifting arrangement. Cutting rate can be precisely set with the help of "Feed Force Dial".

The saw is precisely guided by means of a "Roller guide system" and in addition by a set of Solid Carbide inserts. The blade can be tightened by given correct tension, or loosened with the help of spring loaded hand wheel.

Use of high cutting speeds and using Bimetal blades enables faster cutting. 4 to 5 times more than conventional machines.

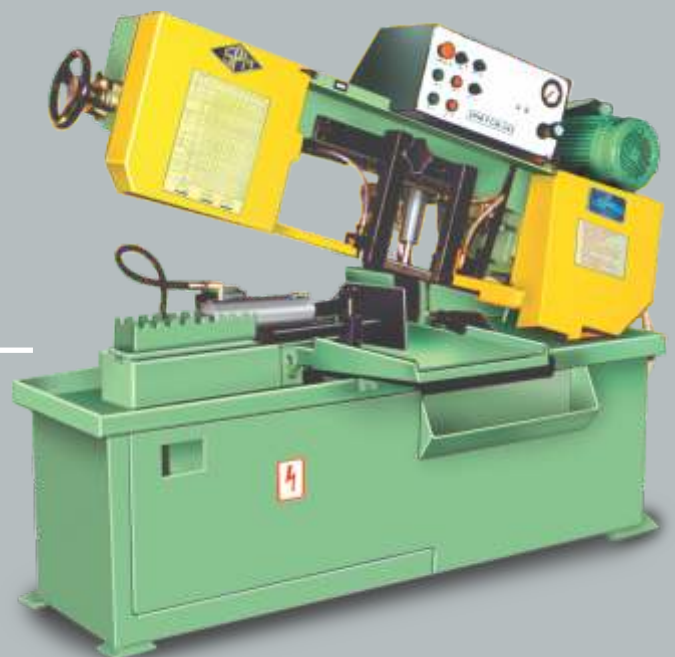



Horizontal Band Sawing Machine, Model FCM-245

Semi Automatic

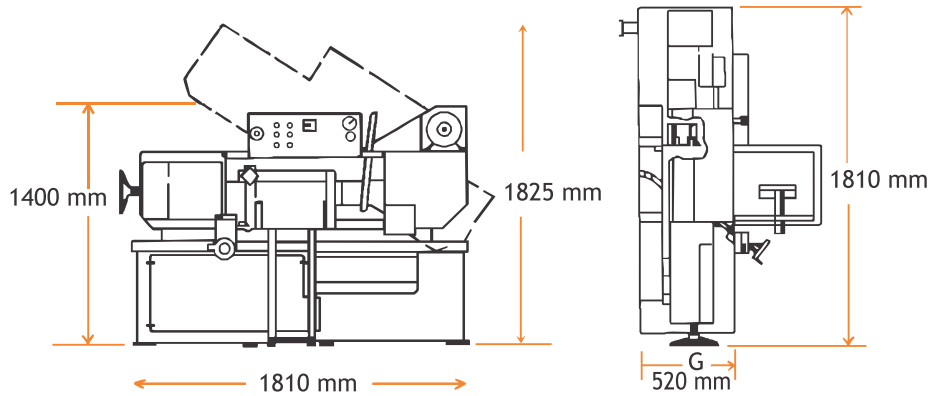

Technical Specifications :

Cutting capacity	245 Ø 230 □
Bimetal blade size	3760 x 27 x 0.9mm
Drive motor	2.2 KW
Hydraulic drive	0.75 KW
Infinitely variable band speed	24-100 m/min
Band tension	Spring loaded hand wheel
Head elevation clamping vice	Hydraulic
Saw feed control	Hydraulic
Floor area	1810 x 520 mm
Machine height	1750 mm
Machine weight (net)	600 kg

Standard Equipments :

- Electrical Control equipments including motors
- Complete hydraulic system
- Push button panel, Feed force dial, Control of cutting pressure.
- Complete coolant system with pump & piping
- Power driven brush for Chip removal
- Blade speed indicator chart
- One bimetal bandsaw blade
- Machine lamp
- Operating tools and spanners

Optional Accessories :

- Roller stock Table for 1500mm
- Chip Conveyor
- Variable Vice Pressure
- Chip Brushes
- Bi-metal Band saw blades

Due to continuous improvement of the product, SPM reserves all rights to change the above specifications without any prior notice.

Swing type dead stop



Infinitely variable band speeds



SPM TOOLS

Corporate Office :

Sector A, Plot No. 4,5,6,7, Parvati Co-op. Ind. Estate,
YADRAV-416 145, Dist : Kolhapur, Maharashtra (INDIA)

T : +91 2322 252590

F : +91 2322 252592

E : marketing@spmttools.in
spmttools.ichal@gmail.com

U : www.spmttools.co.in



FIE Group Company

M/s. Sree Engineers

#11, 3rd Main, 4th Cross, 4th Phase, 7th Block,
Banashankari 3rd Stage, BANGALORE -560085.

T : +91 80 26695857, F : +91 80 26797895

C : +91 9448385857, E : sreeeng@vsnl.net

M/s. RGK Engineering Enterprises (P) Ltd.

No. 218, Karthik Krupa, saraswati Nagar,
Vijay Nagar, BANGALORE -560040.

T : +91 80 23381641, 23303110

F : +91 80 23147882

C : +91 9845018313

E : narayanan_rgk@yahoo.co.in

M/s. Quality Sales & Service

68/3/1A, Bidhan Nagar Road, KOLKATTA -700 007

T : +91 33 23566199, Telefax : +91 33 23566202

C : +91 9433111218

E : quality_org@yahoo.co.in, quality_org@rediffmail.com

M/s. Precimech India (P) Ltd.

A-402, Priyadarshini Society, Plot No. 17,
Patpar Ganj, DELHI-110 092

T : +91 11 65266171, 22611292

C : +91 9810195966, E : pmikuk@gmail.com

M/s. Amey Engineers & Traders

B-23/27, Jeevan Pushpa, Behind Ambika Darshan,
Nana Shankar Seth Road,

DOMBIVLI (W)-421 202, Dist. : Thane

T : +91 251 2480490, F : +91 251 2490918

C : +91 9324803266

E : aet@vsnl.com, ameyengineers@hotmail.com

Pune Region Contact : +91 9881236403